

576

pressure reducing valves



altecnic

# 576 pressure reducing valve



## Design

The series 576 pressure reducing valves are designed to reduce high inlet pressures to a lower downstream pressure, regardless of upstream pressure and flow variations.

The simple and robust design allows stable operation, minimal maintenance as well as installation in various locations.

Product Code	Size	Connections
576062	DN65	Flanged PN16
576082	DN80	Flanged PN16
576102	DN100	Flanged PN16
576122	DN125	Flanged PN16
576152	DN150	Flanged PN16

## Performance and Characteristics

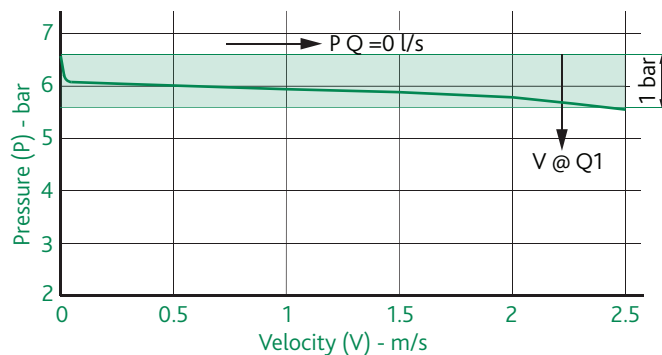

Size	DN	65	80	100	125	150
Q1	l/s	7	11	17	26	38

Q1: flow based on 1 bar pressure drop across the valve

## Technical Data

Max. upstream pressure:	16 bar
Downstream pressure range:	2 to 14 bar
Temperature range:	1° to 60°C
Test:	2014/68/EU
Leakage class:	ANSI/FCI 70-2 Class III

## Dimensions

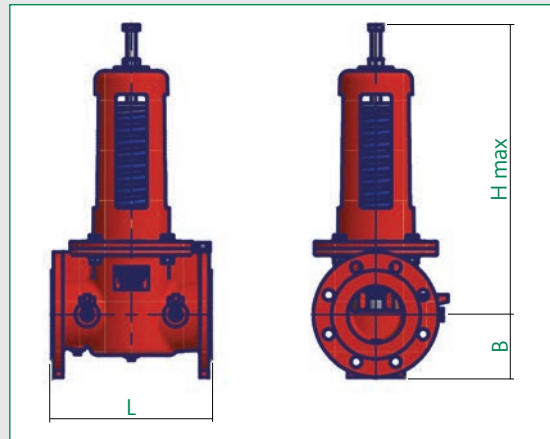

Prod Code	L	B	H	kg
576062	240	93	400	18
576082	260	100	460	27
576102	280	110	575	45
576122	320	125	815	90
576152	350	143	815	100

## Components

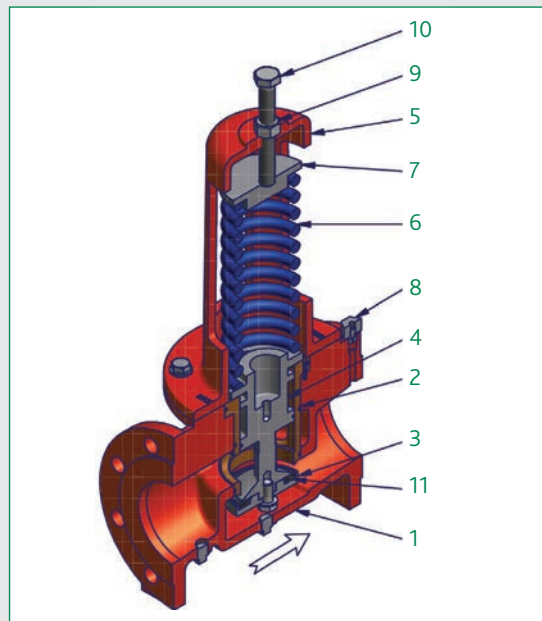

## Construction Details

Item	Component	Material	Grade
1	Body	Ductile iron	GGG40
2	Seat	Stainless steel	AISI 316
3	Disc retainer	Stainless steel	AISI 303/304
4	Piston	Bronze	ASTM B62
5	Cover	Ductile iron	GGG40
6	Spring	Steel	
7	Spring guide	Stainless steel	AISI 303/304
8	Air release plug	Stainless steel	AISI 303/304
9	Locking nut	Stainless steel	AISI 303/304
10	Adjusting screw	Stainless steel	AISI 303/304
11	Gasket	RBR	

# 576 pressure reducing valve

## Installation

It may be necessary to follow codes of practice, to comply with local requirements and to follow the installation procedure supplied with the valve.

The flow direction through the valve is indicated by the flow arrow on the body.

The installation location should be protected against frost and be easily accessible.

We recommend installing a fine filter in front of the pressure reducing valve 576.

A typical installation is shown.

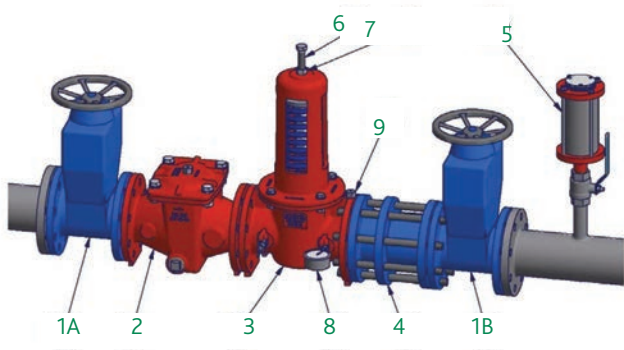

## Components

- 1 Isolating valve
- 2 Filter
- 3 Pressure reducing valve
- 4 Dismantling and adjustment spool
- 5 Air release valve
- 6 Adjusting screw
- 7 Lock nut
- 8 Downstream pressure gauge
- 9 Vent plug

## Installation Continued

- Ensure that the pipeline is clean and there are no foreign particles in the pressure reducing valve.
- Close isolating valve (1A) and (1B).
- Install the pressure reducing valve (3) respecting the flow direction - see flow arrow on the body.

The preferred orientation for the valve is in a horizontal pipeline with the cover directed upwards.

## Commissioning

- Loosen locknut (7).
- Partially open upstream isolating valve (1A).
- Open the venting plug (9) until the pressure reducing valve is fully filled with liquid.
- Partially open downstream isolating valve (1B).
- Adjust downstream pressure using the adjusting screw (6).  
Turn the adjusting screw clockwise to increase the outlet pressure or counterclockwise to reduce the pressure, until the downstream pressure gauge (8) indicates the desired pressure.
- Open isolating valve (1A) completely.
- Open downstream isolating valve (1B) slightly to fill the downstream line.
- Tighten locknut (E).

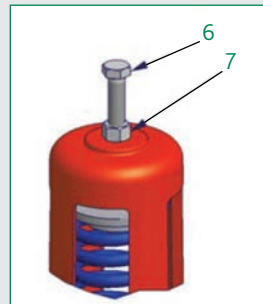

DN	 1 rotation
65 & 80	0.4 bar
100	0.6 bar
125 & 150	0.3 bar

© Patents & Design Altecnic 2019

Altecnic Ltd retains all rights (including patents, designs and copyrights, trademarks and any other intellectual property rights) in relation to all information provided on or via the website, brochures or any other documents, including all texts, graphics and logos, contained on the website, in brochures or in any other documents published in the name of or on behalf of Altecnic Ltd in any form, without prior written consent of Altecnic Ltd.

Altecnic Ltd Mustang Drive, Stafford, Staffordshire ST16 1GW

T: +44 (0)1785 218200 E: sales@altecnic.co.uk

Registered in England No: 2095101

altecnic.co.uk

AL 351 04-11-19

E & O.E

© Altecnic Limited. 2019

ALTECNIC™